

Wednesday 30 April 2008

**MATERIALS PROCESS MODELLING AND FAILURE ANALYSIS**

**Q 1 Solution:**

(a) The process has two planes of symmetry, one vertical and one horizontal, intersecting at the centre of the workpiece. Streamlines of the flow must act along these lines (there can be no flow across a plane of symmetry) so a particle initially in the centre of the workpiece would travel vertically to the mid-point, abruptly turn through a right angle, and then move horizontally to right or left, and exit along the centre-line of the product.

(b) The simplest possible mechanism, and its hodograph are shown below, for the upper left quadrant of the process.

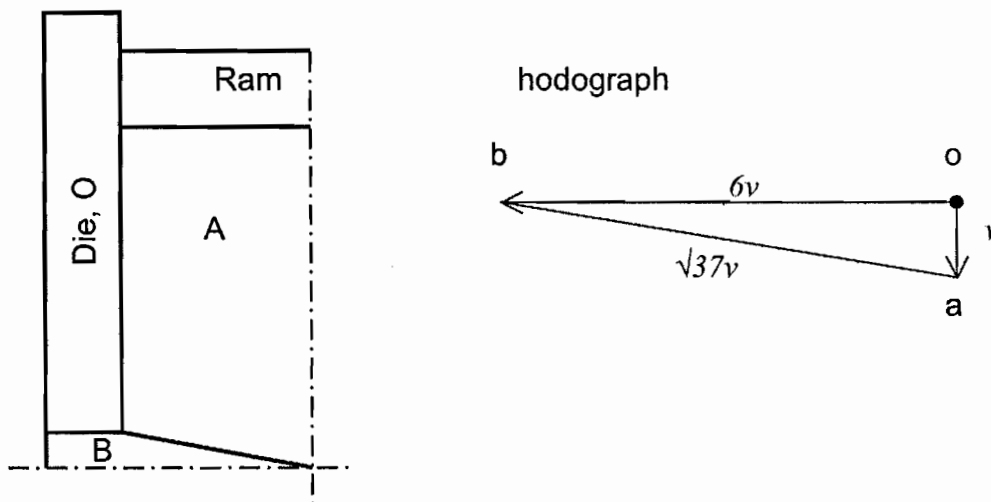

Using the table form of calculation, and remembering that there is no sliding between A and the Ram, and a frictional boundary between the Die O and both A and B:

Interface	Length	Velocity	Internal power
OA	$(x-d)/2$	$v$	$Dkv(x-d)/2$
AB	$\sqrt{37}d/2$	$\sqrt{37}v$	$18.5Dkdv$
OB	$d$	$6v$	$6Dkvd$
<b>Total</b>			<b><math>Dkv(24d+x/2)</math></b>

This is the internal power for one quadrant, so  $P \leq Dk(48d+x)$

(c) The internal power is a function of  $x$ , and thus of time (as  $x=10d - 2vt$ ). Thus, the rate of temperature change is a function of the rate of heat input per unit volume, with the workpiece volume being  $62d^2D$ , so:

$$\frac{dT}{dt} = \frac{\text{heat input rate per unit volume}}{\text{volumetric heat capacity}} = \frac{2Pv}{62d^2D\rho c_p}$$

$$\Rightarrow \frac{dT}{dt} = \frac{kv^2}{31d^2\rho c_p}(48d + x), \text{ where } x = 10d - 2vt, 0 \leq t \leq 9d/2v$$

$$T = T_0 + \frac{kv^2}{31d^2\rho c_p} \int_0^{9d/2v} (58d - 2vt) dt = T_0 + \frac{963kv}{124\rho c_p}$$

(d) This process is difficult to design: the rams must remain symmetrical about the mid-plane at all times, the die must be sufficiently stiff to avoid back-extrusion around the die, and it must be possible to load and unload workpiece and dies.

#### Assessor's report:

22 MET (9 Iia) attempts, average mark 8.3 (10.1)/20, maximum 15, minimum 1.

The answers to parts a and b of this question were generally satisfactory, although many candidates calculated a ram pressure not the ram force as requested. Few candidates performed well in part c in calculating workpiece temperature rise, but part d showed some sensible practical insights into the process.

#### Q2 solution

(a) *Process modelling* provides input to:

- *design* (including selection of material, process route and refinement of geometry)
- *process control and optimization of operating conditions* (improving speed and quality, and reducing manufacturing costs)
- *failure analysis*
- *manufacturing innovation*

Specifically, process modelling provides:

- a means to explore new designs, reducing the need for practical trials
- a means to try new operating regimes without loss of production (targets: lower scrap rates, greater productivity)
- support for re-design of equipment (e.g. dies for hot forming)
- a physical basis for real-time control of processes, and better knowledge of what to control (via sensitivity analysis to changes in input parameters)
- process visualisation, including development of new processes
- prediction of microstructure and properties of final product (both average properties and variability)

- greater understanding of origins of failure – both during processing and later in service (e.g. cracking, distortion, residual stress, porosity)

Advantages of numerical methods (such as FEA) are their ability to handle:

- complexity of geometric shape and boundary conditions
- temperature-dependent properties
- more than one material in the problem (e.g. casting and mould, melt and solid in a casting, metal billet and tools in hot working)
- multi-physics behaviour in a single analysis (e.g. heat transfer, plasticity and microstructural evolution)
- sequential electronic capture of product design from CAD through processing to stress analysis/lifing analysis.

Disadvantages of numerical methods:

- notoriously all-consuming, and often over-kill for the problem in hand (for which a simple analytical solution or experiment may be sufficient).
- cost, particularly in obtaining reliable input data and proper validation.
- produce very convincing looking results quickly (due to pretty front-end computer graphics), leading to erroneous faith in their validity (i.e. “garbage in, garbage out” – the results of numerical computations are no better than the material data, including boundary conditions, and physical assumptions in the model).

(b) Inhibitors are chemicals added to the water (and so only applicable in closed systems where the presence of the inhibitor is acceptable, such as recirculating cooling or heating systems).

An example of an anodic inhibitor is sodium nitrite which acts by forming a continuous protective film of iron oxide on the steel surface which acts as a barrier to further corrosion. The process of forming a protective film is called passivation. However, the inhibitor does this by encouraging oxidation of the steel, and unless the film is sufficiently thick and protective the corrosion rate of the steel is considerably greater than the corrosion rate with no inhibitor present at all. The concentration of the anodic inhibitor must therefore be kept above a critical level – if it falls below this level (by reaction, or by leakage) then very rapid corrosion will result. If the anodic film is incomplete, then this corrosion will be localised in the unprotected regions, and lead to pitting.

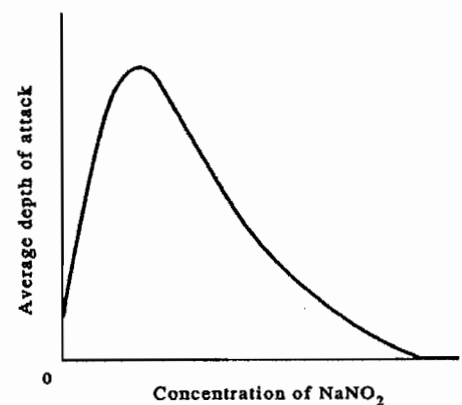

Cathodic inhibitors work by forming surface layers which inhibit the cathodic reaction, and are intrinsically safer – a reduction in concentration will lead to an increased corrosion, but it will still be less than the rate in the absence of the inhibitor.

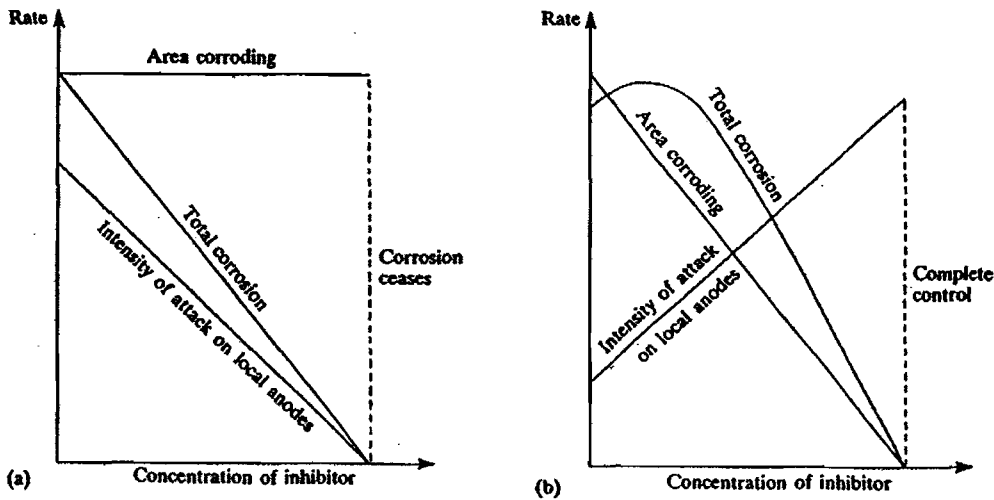

Cathodic inhibition: cathode area reduced progressively by chemical reaction with inhibitor, which forms an impermeable layer. Total corrosion rate and intensity of attack on anode areas (i.e. local corrosion) both fall steadily as concentration of inhibitor rises.

Anodic inhibition: anode area reduced progressively by chemical reaction with inhibitor. However, corrosion becomes increasingly intense at remaining anode areas, until finally all the anode is completely blocked at the critical concentration and corrosion stops abruptly.

For example, consider zinc and iron in contact with each other in water in the presence of air. The standard electrode potentials are as follows:

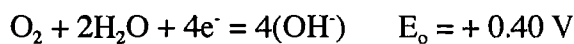

The zinc dissolves to form  $\text{Zn}^{2+}$  ions, releasing electrons. The electrons flow into the iron, which becomes the cathode. On the iron surface, oxygen (dissolved in the water) reacts with water to form hydroxyl ions ( $\text{OH}^-$ ). This uses up electrons, so the corrosion of the zinc continues. If the zinc (with the lower SEP) were not present, the anodic reaction would be oxidation of the iron, which would therefore corrode. The presence of the zinc protects the iron. This is why iron is often **galvanised** (coated with zinc). Galvanised iron will not corrode until most of the zinc has dissolved, even if the zinc covering is incomplete.

Polythene will protect steel by isolating it from its environment. The protection will be complete whilst the polythene layer is intact. If the layer is damaged, then the steel will corrode rapidly (by crevice corrosion).

(c) (i) Drinking water must not be contaminated, so galvanising is unsuitable. Plastic coating is sensible.

(ii) Cathodic inhibition is suitable for a closed central heating system.

**Assessor's report:**

37 (27) attempts, average mark 11.4 (12.6)/20, maximum 17 (17), minimum 6 (7).

All but one candidates attempted this question, which was largely straightforward. Several candidates were confused about the difference between "mathematical", "numerical" and "analytical" models, and credit in part (a) was given for real-life examples. Good answers in part (b) were very similar to the crib. One candidate in part (c) considered the protection of the *outside* of the domestic central heating system against corrosion!

**Q3 SOLUTION**

(a) The decomposition of austenite begins at 723 °C, with diffusive transformations to ferrite/pearlite taking place primarily in the first few hundred °C below this temperature, after which martensite is the likely outcome. Hence the cooling rate in the region of 800-500 °C is the rate through the key temperature interval. In heat treatment the objective is to form martensite; in welding it is the opposite, due to embrittlement.

(b) (i) First two terms of series:

$$\frac{T(t) - T_o}{T_1 - T_o} = \frac{4}{\pi} \left[ \exp\left(-\frac{\pi^2 at}{4l^2}\right) - \frac{1}{3} \exp\left(-\frac{9\pi^2 at}{4l^2}\right) + \dots \right]$$

For ratio of second to first term = 1% (assuming subsequent terms negligible compared to second term):

$$\frac{\frac{1}{3} \exp\left(-\frac{9\pi^2 at}{4l^2}\right)}{\exp\left(-\frac{\pi^2 at}{4l^2}\right)} = \frac{1}{3} \exp\left(-\frac{2\pi^2 at}{l^2}\right) = 0.01$$

Hence:

$$\left(\frac{at}{l^2}\right) = -\frac{\ln(0.03)}{2\pi^2} = 0.178$$

Subsequent terms are clearly negligible, as factor within exponential increases rapidly.

Hence first term for >99% of the solution for  $t > 0.178(l^2 / a)$

Substituting into the temperature solution (first term only):

$$\frac{T(t) - T_o}{T_1 - T_o} = \frac{4}{\pi} \left[ \exp\left(-\frac{\pi^2 at}{4l^2}\right) \right] = \frac{4}{\pi} \left[ \exp\left(-\frac{\pi^2 \times 0.178}{4}\right) \right] = 0.82$$

(ii) Approximate result: 
$$\frac{T(t) - T_o}{T_1 - T_o} = \frac{4}{\pi} \left[ \exp\left(-\frac{\pi^2 a t}{4l^2}\right) \right]$$

Inverting this equation, the time to reach a given temperature T is given by:

$$t = -\frac{4l^2}{\pi^2 a} \ln \left[ \frac{\pi(T - T_o)}{4(T_1 - T_o)} \right]$$

Hence: 
$$\Delta t_{8-5} = t_{500} - t_{800} = \frac{4l^2}{\pi^2 a} \ln \left[ \frac{800 - T_o}{500 - T_o} \right]$$

(c) (i) From (b,i) the same criteria applies – the dimensionless time must exceed the value of 0.178, and this is independent of material.

(ii) As the same criterion applies, so does the solution for the dimensionless temperature

$$\frac{T(t) - T_o}{T_1 - T_o} = 0.82$$

For T = 400°C and T<sub>o</sub> = 20°C, T<sub>1</sub> = 483°C will be the minimum initial temperature to use this solution (typical extrusion temperatures are around 500°C).

(iii) By inspection, substituting the temperatures of 400 and 300 into the solution for  $\Delta t_{8-5}$  :

$$\Delta t_{8-5} = t_{300} - t_{400} = \frac{4l^2}{\pi^2 a} \ln \left[ \frac{400 - T_o}{300 - T_o} \right]$$

(d)

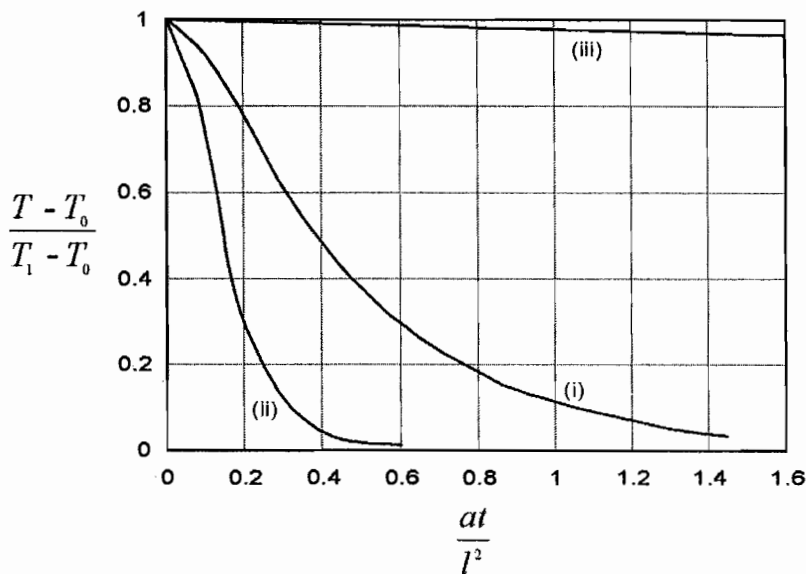
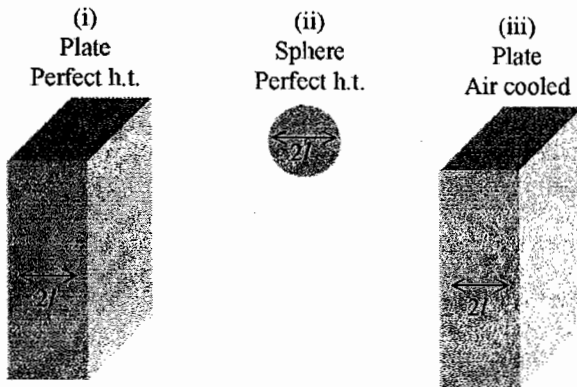

Difference between sphere and plate with perfect heat transfer, of order 2-3 in time. Air cooling very much slower. Heat transfer is much more important than shape in determining the cooling rate.

#### Assessor's report

17 (22) attempts, average mark 10.2 (10.5)/20, maximum 18 (20), minimum 4 (3).

There were a few very good answers to this question, but many showed signs of panic: too much time spent on the first 10% of the marks; more than two pages of derivation without a single word or explanatory indication; lack of thought before starting the algebra.

Answers to part (c) were better than those to part (b).

## Q4 Solution

(a) Failure occurs by stress corrosion cracking (SCC). Essential ingredients:

- Tensile stress
- Generally a small amount of plastic strain
- Specific environment

What is happening? Instead of a crack blunting and so becoming 'safe', failure becomes concentrated at the crack tip. There may be very localised corrosion, or the fracture behaviour may be altered in such a way as to reduce the fracture energy or the fracture stress (probably by the adsorption of ions or atoms onto the material at the crack tip).

Susceptible alloys: Although SCC is found in a huge range of materials, the effects tend to be much more severe in high-strength materials (this has some logical basis: remember that high strength tends to be associated with limited ductility). Typically the metal will be unstable in the environment, but may be protected by a surface film which breaks down locally (e.g. slip steps or microcracks on specimen surface).

e.g. Precipitate Free Zone (PFZ) around grain boundaries in aluminium alloys is associated with SCC in the presence of chloride ions. The PFZ is weaker than surrounding material so plastic deformation is localised there. Slip steps form as dislocations travelling on well-defined slip planes leave the metal. On the edges of these steps the alumina film which normally protects the Al is absent, leaving the Al vulnerable to localised attack. In the presence of chloride ions, the alumina film (which normally forms very rapidly) cannot regenerate.

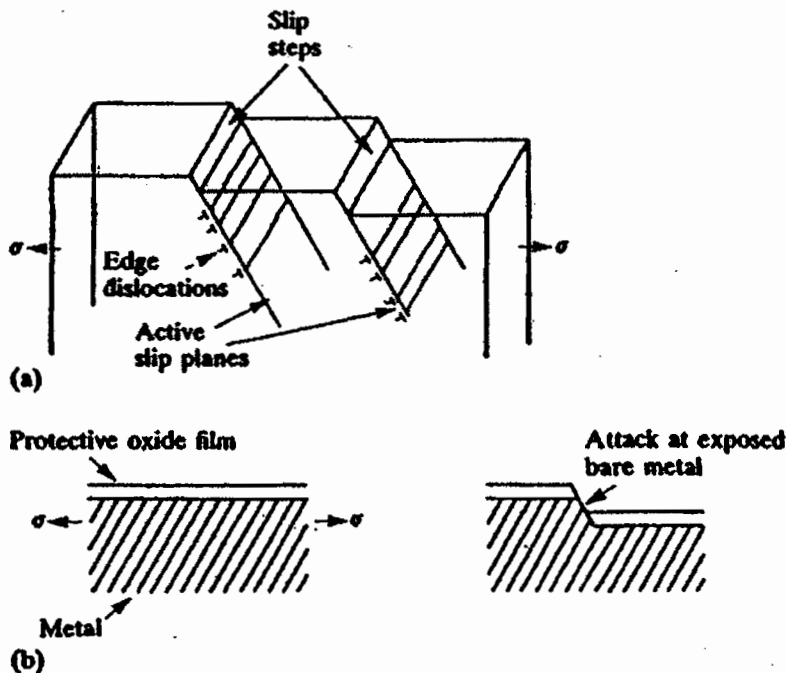

**The role of slip steps in environment-sensitive cracking. (a) The formation of slip steps on the surface of a metal by movement of dislocations along active slip planes under the action of tensile stress. (b) A slip step on the surface of a passivated metal creates an active site for the initiation of a stress-concentrating pit.**



### General Features of SCC failures

- Failures can be intergranular or transgranular, but there is always only very limited ductility and the fracture surfaces have the appearance of brittle fracture.
- **Tensile stress** and the presence of some **specific chemical** (may be very low concentration) in the environment are required. The elimination of **either** removes the problem.

(b) Very thin metal sheet (e.g. aluminium foil) fractures at a low stress (and low fracture toughness) by out-of-plane tearing and shear on planes through the thickness of the sheet, with a very small process zone size.

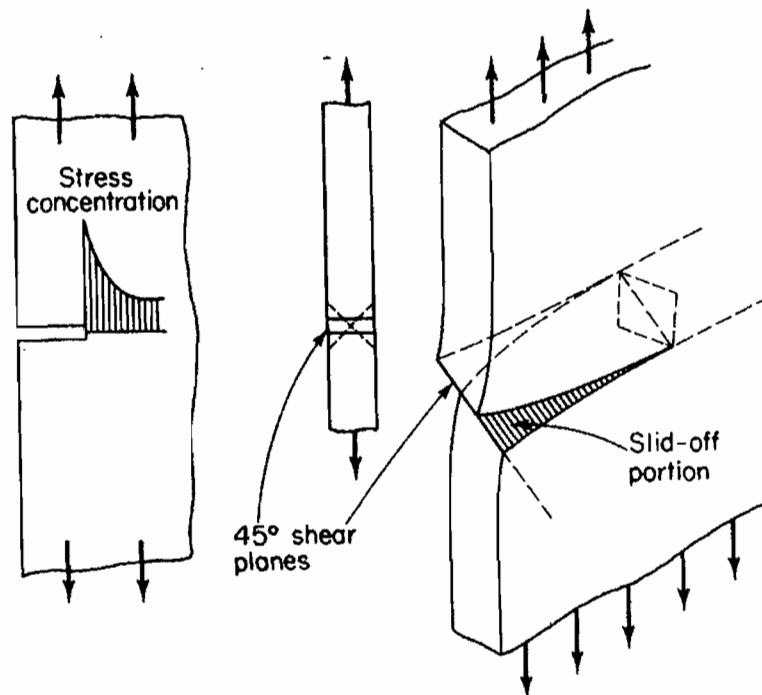

Polymers do not in general suffer out-of-plane tearing because of the effect of molecular alignment and drawing, so the fracture toughness does not fall for very thin specimens. Polymers are therefore more useful for thin-film applications than metals. The specimen thickness at which polymer fracture behaviour changes from the high-energy, ductile fracture typical of thin specimens to the apparently more brittle behaviour typical of thick specimens (i.e. with no macroductility) can be used as a design criterion. A rule-of-thumb used in polymer design is that the material will undergo this transition above a thickness of about  $2(K_{Ic}/\sigma_y)^2$ .

(c) Low-alloy ferritic steels show severe embrittlement during long-term exposure to temperatures between 250 and 400°C (electricity steam turbines operate in this range). This is *temper embrittlement*. Caused by segregation of impurities such as P, Sn, Sb, As to grain boundaries. Fracture becomes brittle and the fracture path *intergranular*, with grain boundary facets. Large grain size means less grain boundary area, so if grain-boundary segregation

occurs there will be higher concentrations of impurities and the effect tends to be stronger. Fine-grained materials tend to have better strength and toughness anyway.

(d) Most 'ordinary' glasses contain sodium as a *network modifier* (breaks up silicate –O-Si-O-Si-O- network, so reduces softening temperatures and promotes a long temperature range in which glass can be worked – see IB notes). If the glass is in contact with moisture (particularly in an acid environment), the sodium atoms which terminate the silicate chains can be replaced by hydrogen atoms:

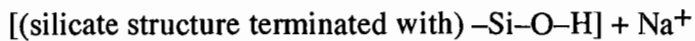
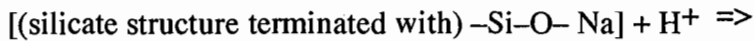

This is associated with shrinkage of the surface layers of the glass. The glass is put into tension and surface cracks form.

The phenomenon of 'static fatigue' occurs when glass under stress suddenly breaking under static load. (n.b. the name is misleading: no cyclic stress is involved.)

Cracks grow slowly in the moist environment, and the material at the crack tips, which is under higher stress because of stress concentration, is particularly susceptible to corrosion. Once one crack reaches critical length, fast fracture takes place.

**Assessor's report:**

38 (29) attempts, average mark 11.4 (11.2)/20, maximum 17 (19), minimum 5 (5).

All candidates attempted this question, which was largely a memory test, and good answers were very close to the crib. Good answers were distinguished by the precision with which they described relevant features of the appropriate mechanism, and poor answers tended to confuse several different mechanisms.