

ENGINEERING TRIPOS PART IA

Monday 11 June 2012 9 to 12

Paper 3

ELECTRICAL AND INFORMATION ENGINEERING

Answer *all* questions.

The *approximate* number of marks allocated to each part of a question is indicated in the right margin.

Answers to questions in each section should be tied together and handed in separately.

There is one attachment for use with Question 6.

STATIONERY REQUIREMENTS

Single-sided script paper

SPECIAL REQUIREMENTS

Engineering Data Book

CUED approved calculator allowed

You may not start to read the questions printed on the subsequent pages of this question paper until instructed that you may do so by the Invigilator

SECTION A

1 (**long**) Figure 1(a) shows the circuit for a source follower amplifier. The FET has small-signal parameters $g_m = 5 \text{ mS}$ and $r_d = 15 \text{ k}\Omega$. The source resistor $R_S = 6 \text{ k}\Omega$, and the gate resistor $R_G = 2 \text{ M}\Omega$.

(a) Calculate the gain and output impedance of the circuit. [15]

(b) As a result of electrical interference, noise in the form of a small voltage of frequency 200 Hz is induced in the drain circuit of the FET. The presence of the 200 Hz noise can be modelled by the inclusion of a small signal source V_N in the drain circuit as shown in Figure 1(b).

Draw the small signal equivalent circuit for determining the component of the output voltage that arises as a result of the noise source. [5]

(c) Determine the maximum amplitude of V_N in Figure 1(b), if the noise component of the amplifier's output is not to exceed $30 \mu\text{V}$. [10]

(CONTINUED)

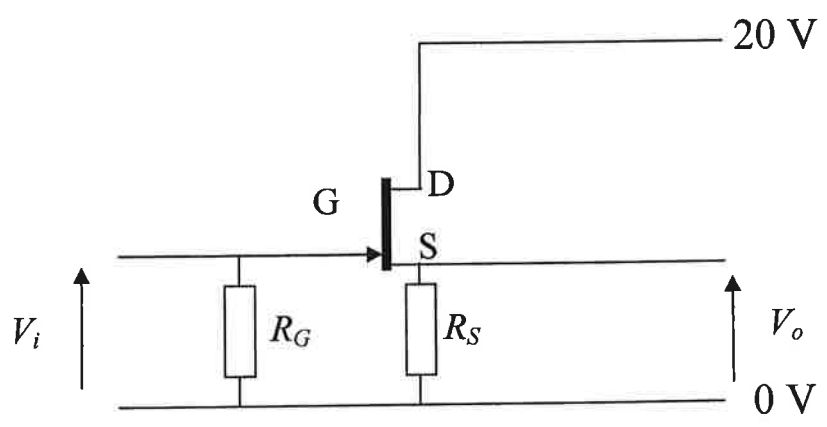

Figure 1(a)

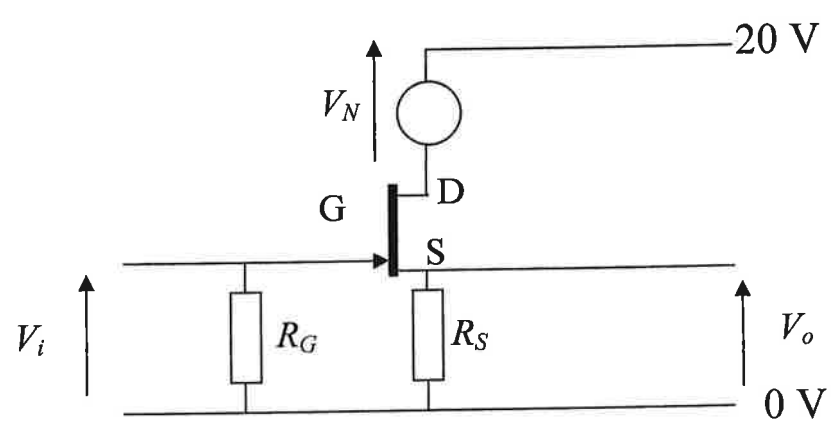

Figure 1(b)

2 (long) Consider the amplifier circuit in Figure 2.

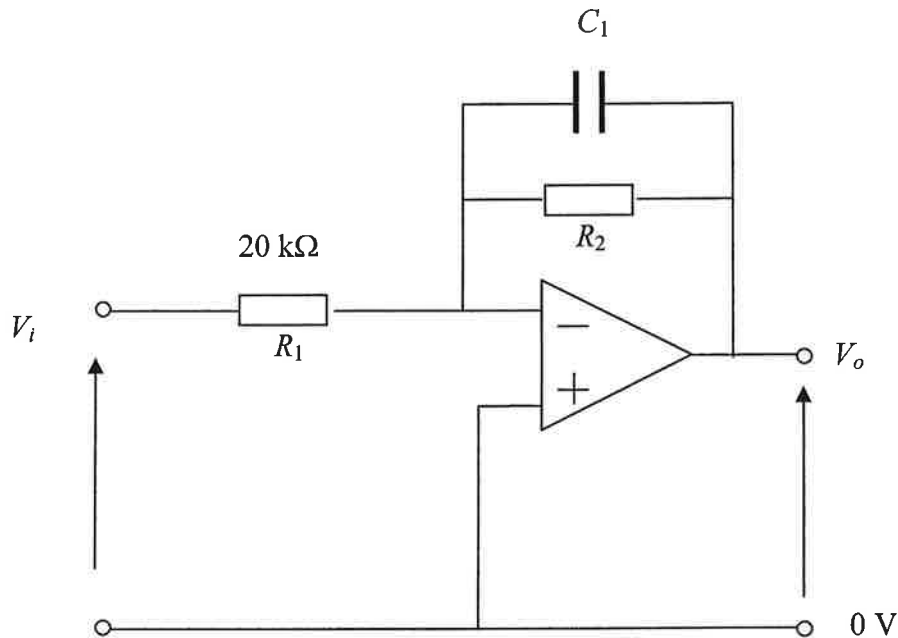

Figure 2

- (a) At a mid-band frequency where C_1 may be considered an open circuit, calculate the value of R_2 required to give a voltage gain of 50 dB between input and output. The operational amplifier may be considered ideal. [8]
- (b) What is the mid-band input impedance of the circuit? [2]
- (c) Calculate the value of C_1 required to have a 3 dB high frequency cut-off of 6 kHz, i.e. where the circuit gain drops to $\frac{1}{\sqrt{2}}$ of its mid-band value. [5]
- (d) If a practical operational amplifier has an open loop voltage gain of 20,000 and an output impedance of 50Ω , but is otherwise ideal, what is the actual mid-band voltage gain in dB when the circuit drives a load impedance of 25Ω ? [15]

3 (short)

(a) What are copper loss and iron loss in the context of power transformers? Indicate how each of these corresponds to elements of a simple transformer equivalent circuit, and explain how each may be measured. [3]

(b) A transformer consumes real and reactive power of 3 kW and 3 kVAR respectively when providing its full load of 70 kVA with a lagging power factor of 0.9 at 200 V and 50 Hz. Under these conditions it may be assumed that copper and iron losses are equal, that the reactive power of the magnetising reactance and leakage reactances are equal, and that the supply has very low impedance. Calculate the output voltage under no-load conditions. [7]

4 (short) A battery, modelled as a 12 V e.m.f. in series with a resistance of $2\ \Omega$, is being charged by a constant current source through the network shown in Figure 4. The multirange ammeter A_m used to measure the battery current drops a voltage of 1 V at full scale deflection on all ranges. Here it is set to its 10 A range and reads 1 A.

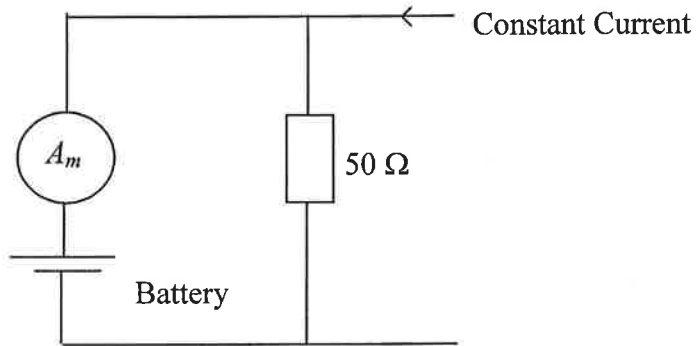

Figure 4

- (a) What is the value of the constant current supply? [5]
- (b) What would be the current into the battery if the ammeter was replaced with a wire of zero resistance? [5]

5 (short) A small crane lifts a mass of 2 kg at a speed of 0.5 m s^{-1} . There are no motor power losses, and the crane's 50 Hz AC motor can be modelled as an inductance $L = 50 \text{ mH}$ in series with a resistor R , where the latter models the conversion of the electrical input power to the mechanical output power of the motor.

(a) If the input current is 2 A when lifting this load, what is the power factor of this circuit? [5]

(b) If the crane is driven by a higher voltage AC supply through an ideal step-down transformer with a turns ratio of 30:1, what capacitance should be placed across the transformer's high voltage terminals to give the circuit a power factor of unity? [5]

SECTION B

6 (short) Figure 6(a) shows a logic circuit incorporating NMOS transistors only whilst Figure 6(b) shows a second circuit incorporating both PMOS and NMOS transistors.

(a) Identify the Boolean logic functions implemented by the two circuits. [2]

(b) Using the NMOS characteristic given in Figure 6(c), find the output voltage for the circuit in Figure 6(a) for input voltages of 0, 2, 5, 8 and 10 V. Sketch the input versus output voltage transfer characteristic. [6]

(c) Explain the advantages that CMOS logic circuitry exhibits compared to NMOS circuitry. [2]

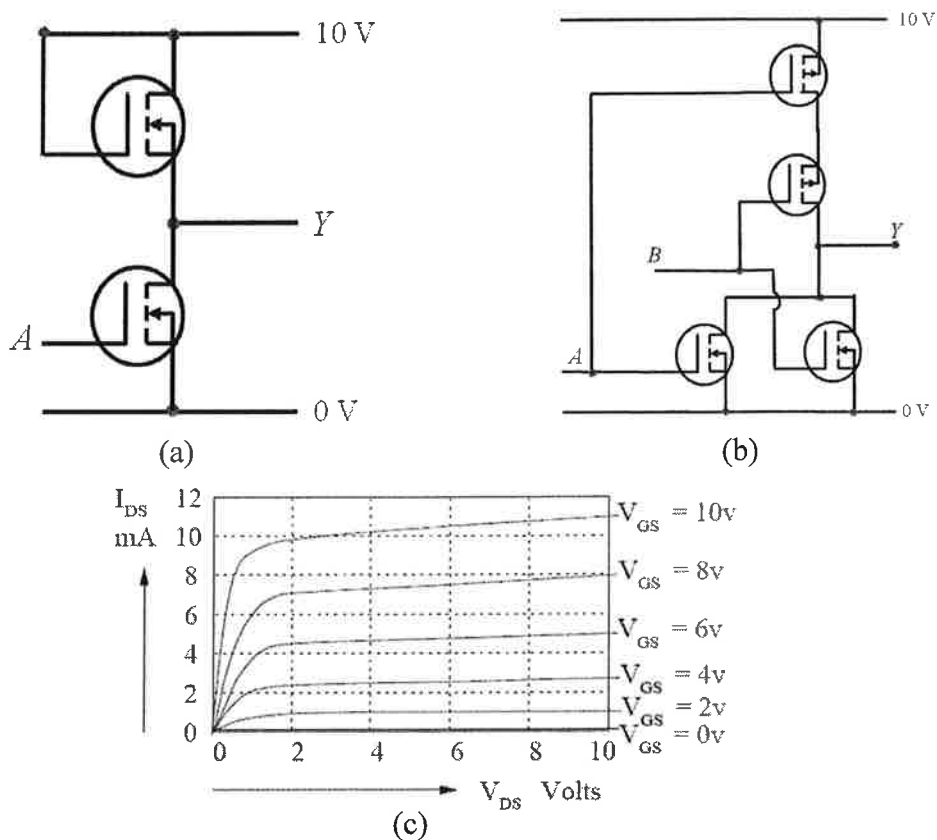

Figure 6

NB The graph in Figure 6(c) is reproduced at the end of the paper to help in answering the question.

7 (short) A synchronous Johnson counter is formed by connecting the complement of the output of a 4-stage shift register to its input.

(a) Write down the allowable sequence or sequences. [4]

(b) The Johnson counter is to be used as part of a decimal counter which counts from 0 to 7. For the sequence beginning ABCD = 0000, use this binary number to represent the decimal number 0, the next binary number in the sequence to represent the decimal number 1 and so on. Derive, using a Karnaugh map or otherwise, the simplest Boolean expressions for each of the first four decimal numbers (0-3) in the sequence which have the counter stages A-D as their inputs. [6]

8 (short) Before the following PIC12F629 code is executed, the contents of memory locations 0x30 and 0x31 are the decimal numbers 20 and 50 respectively.

```

main      movlw 0x31 ;
            movwf FSR ;
            call sr ;
            decf FSR ;
            call sr ;
end      sleep ;
            .....

sr       rrf INDF ;
            movlw 0x10 ;
            addwf INDF ;
            return ;

```

(a) What are the contents of W and memory locations 0x30 and 0x31 after the code has executed. [5]

(b) Determine the time taken to execute the code assuming a 20 MHz clock. [5]

9 (long) An industrial metal alloy processing plant control system contains a heater (H), a temperature sensor (S), a timer (T) and an alarm (A) to alert the control room that the process has finished. When a button switch (B) is pressed, switching its output from 0 to 1, the digital control system resets the timer ($T = 0$) and turns on the heater ($H = 1$) at the rising edge of the next clock pulse. Whilst the process temperature is below the target temperature, which you may assume is significantly above ambient, the temperature sensor has an output 0. This changes to 1 when the process temperature goes above the target temperature, at which point the heater is turned off ($H = 0$). After cooling, the process temperature falls below the target temperature, the sensor output changes to 0 and the heater is again turned on. This heating-cooling cycle continues until the process time is complete, at which point the timer output changes from 0 to 1, the heater is turned off and the alarm is sounded. The switch B is then pressed (switching its output from 1 to 0) to return the processing plant to its starting state.

You may assume that once the process is initiated, the button switch cannot be turned off until the process cycle ends and that the process time is significantly longer than the clock period.

- (a) Draw a state diagram for the control system for the processing plant. [10]
- (b) Determine the number of bistables needed for the control system. [2]
- (c) Compile the state transition table. [10]
- (d) Derive the bistable and the output logic. You do not need to draw a circuit diagram for the control system. [8]

SECTION C

10 (short)

(a) Sketch the electrical field lines and directions for the following charged objects:

- (i) an isolated point charge of magnitude $+Q$ C
- (ii) a line of charge with a charge density of $-\lambda$ C m⁻¹

NB you do not have to obtain algebraic expressions for the fields. [2]

(b) Two point charges are placed on a two dimensional (x,y) plane with dimensions measured in centimetres. The value and position of each charge are as follows:

Charge 1: $10 \mu\text{C}$ (1,0)
Charge 2: $-3 \mu\text{C}$ (0,1)

- (i) Calculate the electric field at the origin. [5]
- (ii) A third charge of value $-2 \mu\text{C}$ is placed at the origin. Calculate the electrostatic force it experiences. [3]

11 (**short**) A toroidal ring made from 4% silicon-iron has a mean diameter of 400 mm and a uniform cross-sectional area of 100 mm^2 . A 2 mm gap is formed in the toroid. A 400 turn coil, carrying a current of 4 A, is wound around it as shown in Figure 11.

(a) Calculate the magnetic flux density in the air gap. [6]

(b) A 10 turn coil of cross sectional area 1 mm^2 is placed at the centre of the air gap and orientated so that its axis is parallel to the magnetic field lines in the gap. The current in the 400 turn coil is reduced to zero over a time of 2 ms. What is the average voltage induced across the terminals of the small coil? [4]

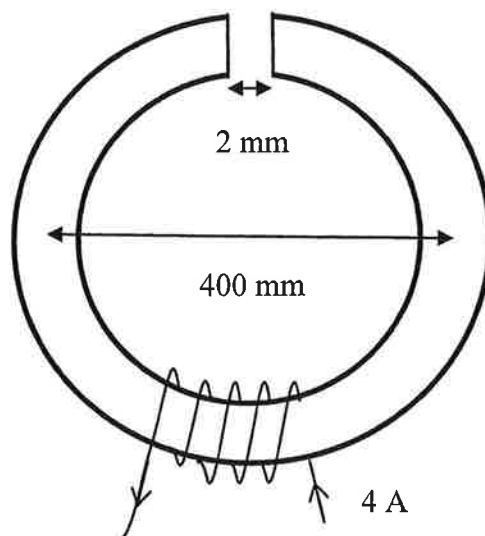

Figure 11

12 (long)

(a) A long, hollow conducting pipe of inner radius r_a and outer radius r_b carries a current I parallel to its axis and distributed uniformly throughout the material of the pipe.

(i) Derive an expression for the current density in the pipe. [3]

(ii) Using Ampere's law, or otherwise, obtain expressions for the magnetic flux density for $r < r_a$, for $r_a < r < r_b$ and for $r > r_b$. [15]

You may assume that the value for relative permeability is 1 everywhere.

(b) A flat conducting spring of spring constant 30 N m^{-1} consists of two 5 cm diameter turns. In its unstretched state, the turns are nearly touching. A 10 g mass is hung from the spring and then a current is passed through it as shown schematically in Figure 12. The spring stretches by 1 mm.

Calculate the current in the spring.

You may assume that the spring has negligible mass and that fringing effects may be ignored. NB the electrical contacts to the spring are not shown in Figure 12 for simplicity. [12]

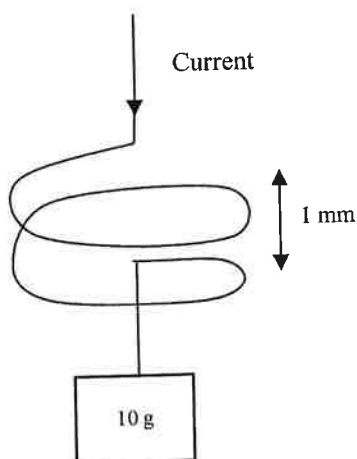

Figure 12

END OF PAPER

THIS PAGE IS INTENTIONALLY BLANK

PART IA Paper 3 Q6

Candidate Number _____

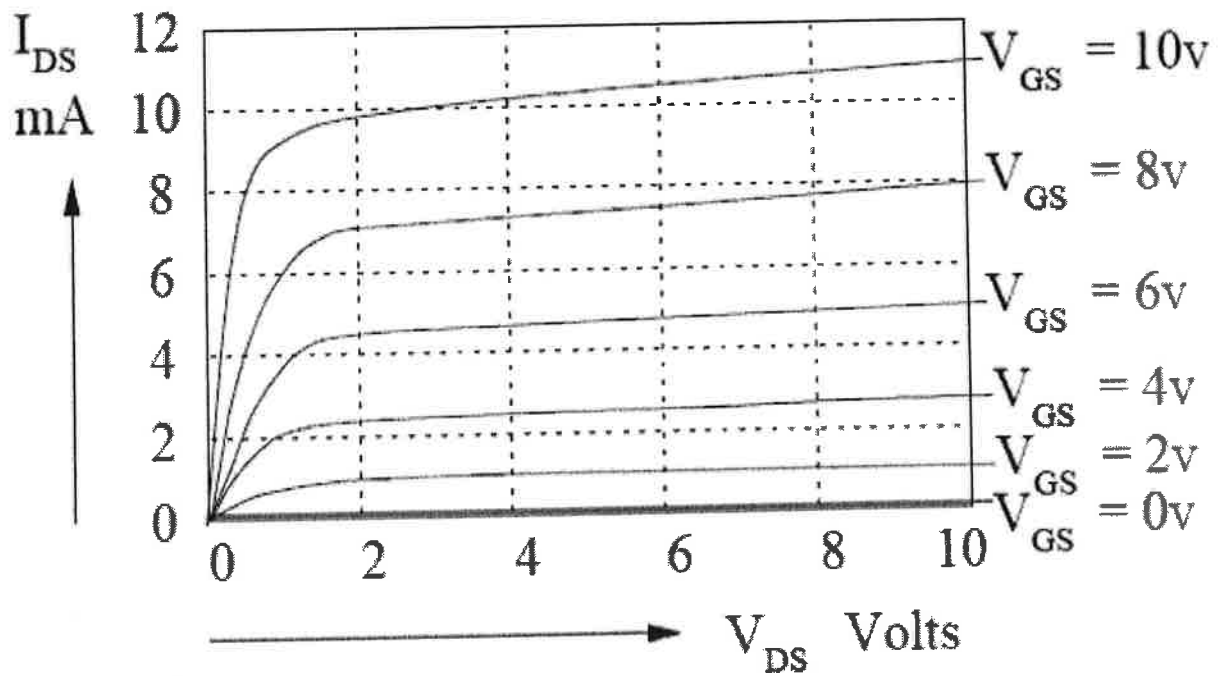

NOTE: The graph in Figure 6(c) is reproduced here. You should use this to help you complete Question 6. You must attach this sheet to your answer.

Paper 3 2012, Sections B&C short answers

6a) $\overline{V_{IE}}, \overline{A + E}$

7b) $\overline{A}, \overline{B}, \overline{A}, \overline{B}, \overline{B}, \overline{C}, \overline{A}, \overline{D}$

8a) 0x1A, 0x29, 0x10

b) 900 ns

9b) 2

c), d) multiple correct answers depending on state allocations.

10 b) i) $-898 \hat{i} + 269 \hat{j}$ MV / m

ii) $1800 \hat{i} - 539 \hat{j}$ N

11 a) 0.9 T

b) 4.5 mV

11 a) i) $\frac{I}{\pi(r_b^2 - r_a^2)}$

ii) 0, $\frac{\mu_0}{2\pi r} \left(\frac{r^2 - r_a^2}{r_b^2 - r_a^2} \right) I$, $\frac{\mu_0 I}{2\pi r}$

b) 46.6 A

Short Answers-Part IA, Paper 3, Section A 2012

Q1:

a) Gain=0.955; $R_{out}=191\Omega$

c) 2.34mV

Q2:

a) $R_2=6.33M\Omega$

b) 20k Ω

c) $C_1=4.19pF$

d) 49.6

Q3:

b) 206V

Q4:

a) 1.282 A

b) 1A

Q5:

a) 0.154

b) 2.2×10^{-7} F