

Wednesday 1 June 2016 9 to 12

Paper 1

MECHANICAL ENGINEERING

Answer *all* questions.

The *approximate* number of marks allocated to each part of a question is indicated in the right margin.

Answers to questions in each section should be tied together and handed in separately.

Write your candidate number ***not*** your name on the cover sheet.

STATIONERY REQUIREMENTS

Single-sided script paper

SPECIAL REQUIREMENTS TO BE SUPPLIED FOR THIS EXAM

CUED approved calculator allowed

Engineering Data Book

10 minutes reading time is allowed for this paper.

You may not start to read the questions printed on the subsequent pages of this question paper until instructed to do so.

SECTION A

1 (**short**) The hinged, rectangular gate shown in Fig. 1 has a width w into the page, and retains water of density ρ that reaches a height h .

(a) Find an expression for the total hydrostatic force acting on the gate. [4]

(b) Find an expression for the reaction R necessary to keep the gate closed as a function of the water height h . For values of h between 0 and $4L$, sketch $R(h)$. [6]

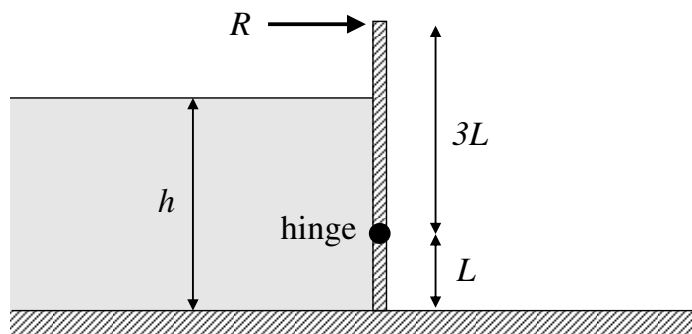

Fig. 1

2 (**short**) A fluid of density ρ flows through a pipe at velocity V_1 . A contraction is installed in the pipe between sections 1 and 2, as shown in Fig. 2. The contraction is smooth enough to neglect dissipation in it. The jet formed at the subsequent abrupt expansion has uniform velocity and runs parallel to the pipe axis. The pressures p_1 and p_2 are uniform across each section, and the pressure at the back face of the expansion can be assumed to be also p_2 . At section 3, the flow can be considered uniform again.

(a) Can Bernoulli's equation be applied between sections 1 and 2? Show that

$$p_1 - p_2 = \frac{1}{2}\rho V_1^2 K_1,$$

and give the value of the parameter K_1 , which depends only on A_1 and A_2 . [5]

(b) Can Bernoulli's equation be applied between sections 2 and 3? By choosing an appropriate control volume, show that

$$p_3 - p_2 = \frac{1}{2}\rho V_1^2 K_2,$$

and give the value of the parameter K_2 , which depends only on A_1 and A_2 . [5]

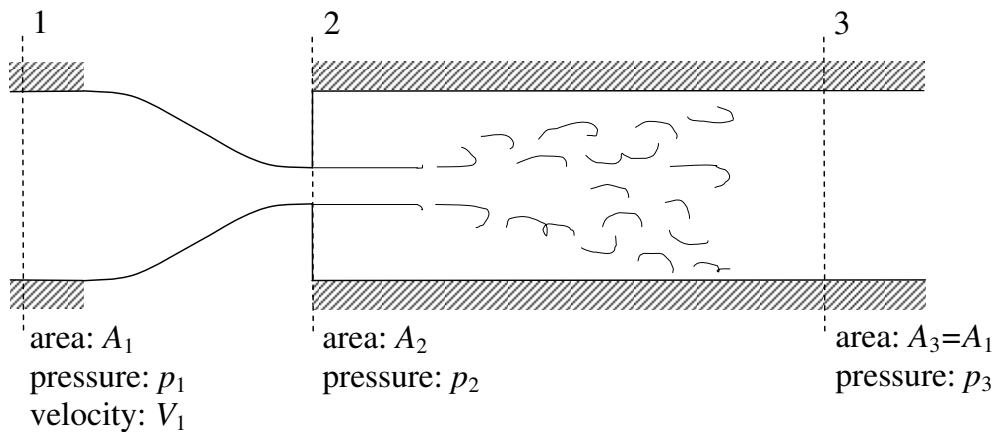

Fig. 2

3 **(long)** A cylindrical beaker of radius R and height H contains water up to height h_0 when at rest, as shown in Fig. 3(a). When the beaker rotates about its axis at a constant angular velocity ω , the water inside reaches a steady motion rotating at the same angular velocity as the beaker, as shown in Fig. 3(b). When rotating at an angular velocity ω , the maximum water height above the bottom of the beaker is h_1 , and the depth of water is large enough that the free surface never reaches the bottom of the beaker.

(a) By considering the radial pressure forces on a small fluid particle a distance r from the axis of rotation, or otherwise, derive a differential equation for the radial variations of the pressure. Integrate it to find the pressure difference between points A and B ($p_B - p_A$) in Fig. 3(b). [8]

(b) By considering the hydrostatic variations of the pressure, obtain an expression for the height of the free surface above its lowest point, $\Delta h(r)$. [8]

(c) Using continuity, or otherwise, show that the maximum height of the liquid has the form

$$h_1 = h_0 + C_1 \frac{\omega^2 R^2}{g},$$

where g is the acceleration of gravity. Find the value of the constant C_1 . What is the maximum possible ω to avoid spilling water? [10]

(d) The conical beaker shown in Fig. 4 is tall enough that when rotating at large ω the free surface does not reach the rim. However, this alone does not guarantee that no water will be spilled. What other condition does the curve $\Delta h(r)$ need to satisfy at $r = h_1$ for the analysis to hold, the solution to be stable, and no water to escape the volume? Express the condition in terms of h_1 , ω and g . [4]

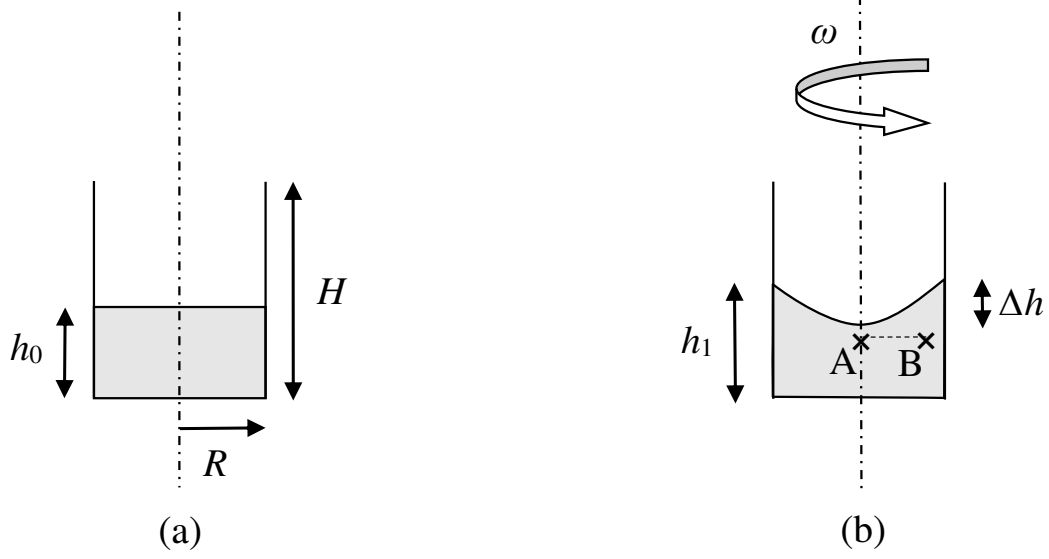

Fig. 3

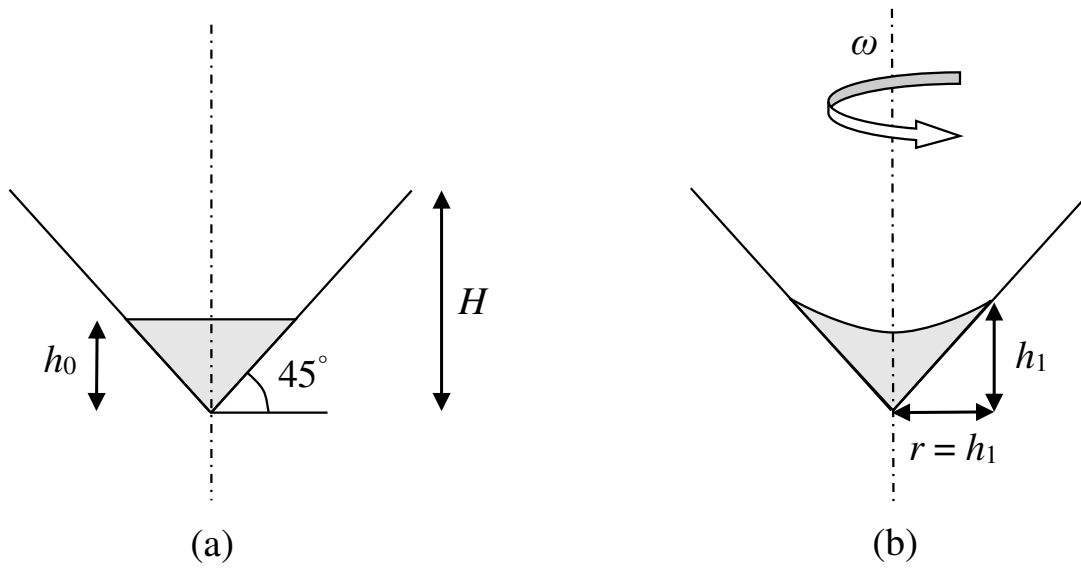

Fig. 4

4 (**short**) Consider air (taken as a perfect gas) undergoing compression from ambient conditions, $T_1 = 300 \text{ K}$ and $p_1 = 1 \text{ bar}$, to a final pressure of $p_2 = 4.5 \text{ bar}$ with negligible changes in kinetic and potential energy.

(a) Assuming the process is reversible and adiabatic, calculate the specific work required on the air. [4]

(b) If the process is adiabatic but not reversible and the specific work done on the air is $w = 200 \text{ kJ kg}^{-1}$, determine the final temperature and specific entropy increase during this process. [6]

5 (**short**) A spherical thin balloon expands from volume $V_1 = 1$ litre to $V_2 = 5$ litres by the addition of $Q = 560$ J of heat. The balloon material resists expansion of the surface area A , resulting in work done by the gas of $W = p_{\text{atm}}\Delta V + \sigma\Delta A$, where ΔV is the change in volume, σ is the surface tension and ΔA is the change in surface area of the balloon. Assume that the balloon is filled with air (taken as a perfect gas) initially at temperature $T_1 = 200$ K and $p_1 = 1$ bar, and expands against a constant atmospheric pressure of $p_{\text{atm}} = 1$ bar.

(a) Calculate the mass of air within the balloon. [4]

(b) Calculate the final temperature when the surface tension of the balloon is $\sigma = 100 \text{ N m}^{-1}$. [6]

6 (long) Consider the air-standard Stirling cycle, which is the same as the Otto cycle *except* that compression and expansion occur isothermally rather than adiabatically.

(a) Sketch the cycle on a pressure - volume diagram and label the following points: 1 – beginning of compression; 2 – end of compression; 3 – beginning of expansion; 4 – end of expansion. Label the heat transfer as positive (in) or negative (out) for each process. [5]

(b) For a Stirling engine cycle using a perfect gas and a fixed volumetric compression ratio r_v , operating between two reservoirs of high T_h , and low T_l , temperatures, show that the inward specific heating for the cycle is $q_{in} = k_1 T_h - k_2 T_l$. Find k_1 and k_2 in terms of r_v , specific heat capacity c_v , and gas constant R . [5]

(c) Consider a Stirling engine cycle operating with air (taken as a perfect gas) where the state at the beginning of the isothermal compression process is $p_1 = 100$ kPa, $T_l = 300$ K, $r_v = 6$, and the maximum temperature in the cycle is $T_h = 1400$ K.

(i) Calculate the thermal efficiency of the cycle. Assume that no heat is recycled. [6]

(ii) Calculate the thermal efficiency of the cycle assuming an ideal regenerator, where the heat added from point 2 to 3 is supplied by the rejected heat from 4 to 1. [6]

(d) Determine the heat transferred into the engine and thermal efficiency of the engine, treating the air in the engine as a semi-perfect gas where the specific heat capacity is given as $c_v = \alpha + \beta T + \gamma T^2$, where $\alpha = 610$ J kg⁻¹ K⁻¹, $\beta = 0.3$ J kg⁻¹ K⁻², $\gamma = 7 \times 10^{-5}$ J kg⁻¹ K⁻³. Assume no heat is recycled. [8]

SECTION B

7 (**short**) The frictionless mechanism ABC shown in Fig. 5 is used to lift a body of mass m connected to the pin joint at B by a light, inextensible cable. The mechanism consists of two light, rigid bars AB and BC , each of length L .

For the case in which A and C each move with absolute speed $v/2$ in the direction of the applied forces H :

(a) Sketch the velocity diagram. [5]

(b) Determine the force H and the vertical support reactions V . [5]

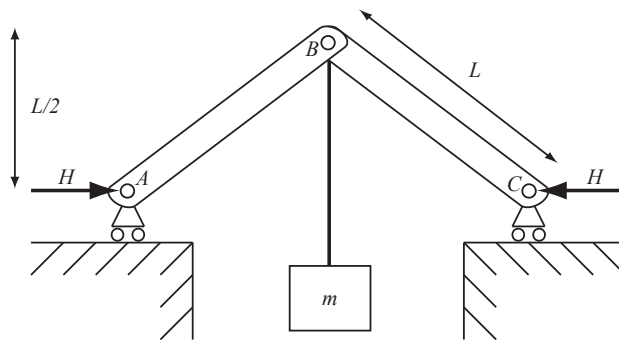

(not to scale)

Fig. 5

8 (**short**) A tractor of mass $2m$ attempts to tow a small car of mass m on a frictionless horizontal road by means of a light, elastic cable. The cable is initially slack as the tractor starts to move with speed v . The cable then goes taut and the car begins to move.

(a) Calculate the elastic potential energy in the cable at the point of maximum extension of the cable. [8]

(b) Briefly explain what will happen to the elastic potential energy in the cable if the cable snaps at the point of maximum extension of the cable. [2]

9 (long) Three children, A , B and C , are playing a running game, as viewed from above in Fig. 6. At the instant shown, B is 7 m from both A and C , who are approximately 10 m apart. In absolute terms, A is running in a circular path centred on the indicated position of C at 2 m s^{-1} and accelerating along that path at 1 m s^{-2} . In absolute terms, B is running in the \mathbf{j} direction at constant 2 m s^{-1} , and C is running in the \mathbf{i} direction at 2 m s^{-1} and accelerating at 0.5 m s^{-2} in the \mathbf{i} direction.

(a) Write down, in vector terms, the absolute velocities and accelerations of each of the three children separately. [6]

(b) Calculate the velocities of both A and B relative to C . [6]

(c) Calculate the accelerations of both A and B relative to C . [6]

(d) At the instant shown in Fig. 6, A throws a ball such that the velocity of the ball relative to the velocity of A is in the \overline{AC} direction, but the ball is subsequently caught by B . By carefully considering the velocity of the ball, calculate how far B has run by the time she catches the ball. You may neglect both gravity and air resistance and assume that all movement is in the plane shown. [12]

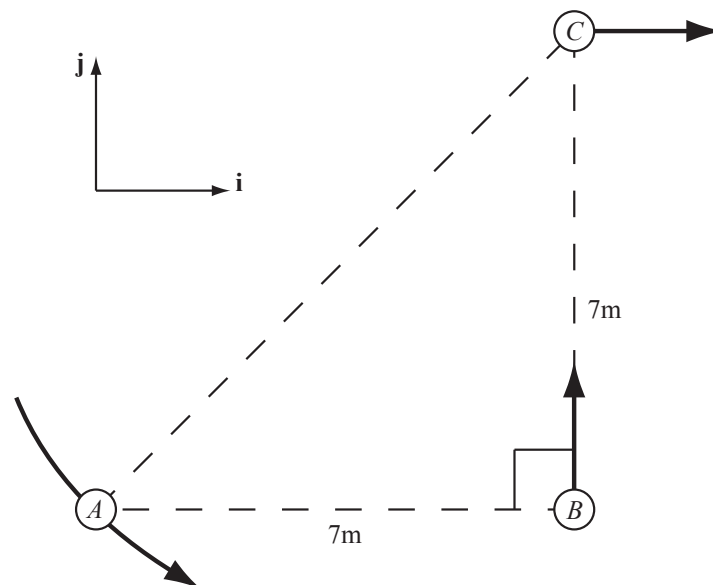

(not to scale)

Fig. 6

10 (**short**) A satellite of mass m is in an elliptical orbit around Earth. At its perigee (point of closest approach) it has an altitude of 1200 km and a speed of 7900 m s^{-1} . The radius of Earth is 6400 km, the mass of Earth is $6 \times 10^{24} \text{ kg}$ and the gravitational constant G is $6.67 \times 10^{-11} \text{ m}^3 \text{ kg}^{-1} \text{ s}^{-2}$.

(a) If the work done on the satellite to put it into orbit was $1 \times 10^{11} \text{ J}$, determine the mass of the satellite. [6]

(b) If the velocity of the satellite is 5431 m s^{-1} at its apogee (point on its orbit furthest from Earth), determine its altitude at this point. [4]

11 (**short**) Figure 7 shows a mass–spring–dashpot system, where f is an applied force, m is the mass of the body, k is the spring stiffness and λ is the viscosity of the dashpot.

(a) Derive the equation of motion for this system. [5]

(b) If $f = F \sin(0.8\omega_n t)$, where F is constant, ω_n is the natural frequency and t is time, estimate the minimum required damping factor such that the amplitude of the response does not exceed $1.2F/k$. [5]

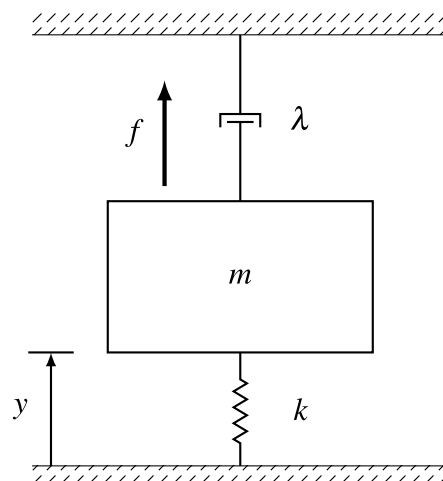

Fig. 7

12 (**long**) Consider the mass–spring–dashpot system shown in Fig. 8, where f_1 is an applied force, m_1 and m_2 are the masses of the bodies, k_1 and k_2 are spring stiffnesses, and λ is the dashpot viscosity.

(a) The equation of motion can be expressed in the form

$$\mathbf{M}\ddot{\mathbf{y}} + \mathbf{C}\dot{\mathbf{y}} + \mathbf{K}\mathbf{y} = \mathbf{f},$$

where the vector \mathbf{y} contains the displacement of each body. Formulate the matrices \mathbf{M} , \mathbf{C} and \mathbf{K} , and the vector \mathbf{f} . [6]

(b) For the case $\lambda = 0$, find the natural frequencies of the system when $k_1 = k_2$. [8]

(c) For the case $\lambda = 0$, determine the mode shapes when $k_1 = k_2$. [6]

(d) Consider the case $\lambda = 0$, $k_1 = k$, $k_2 = 2k$, $m_1 = m_2$ and $f_1 = 0$. The springs are unstretched when $\mathbf{y} = [0, 0]^T$. For the initial conditions $\mathbf{y}_0 = [1, 1]^T$ and $\dot{\mathbf{y}}_0 = [0, 1]^T$, find an expression for the response of the system as a function of time. [10]

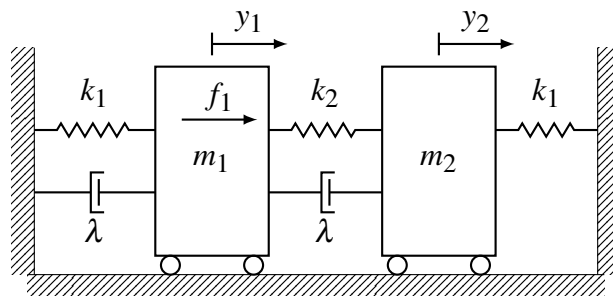

Fig. 8

END OF PAPER